

1.

[2 marks]

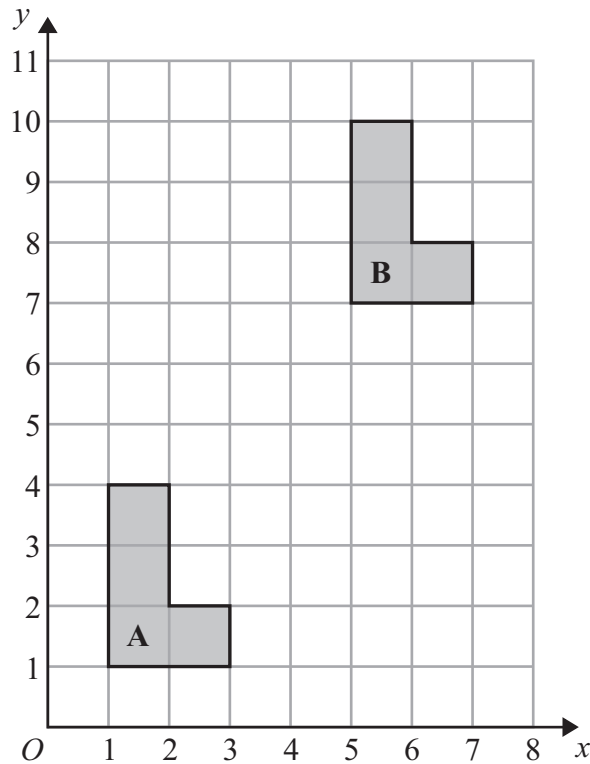

Describe fully the single transformation that maps shape **A** onto shape **B**.

.....

.....

2.

[2 marks]

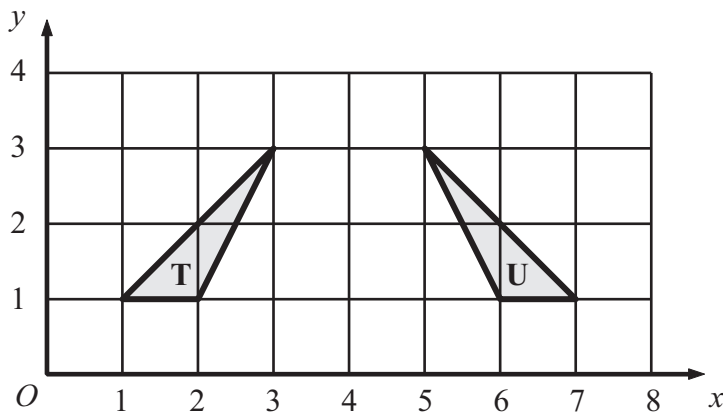

Describe fully the single transformation which maps triangle **T** onto triangle **U**.

.....

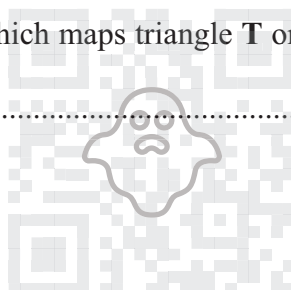

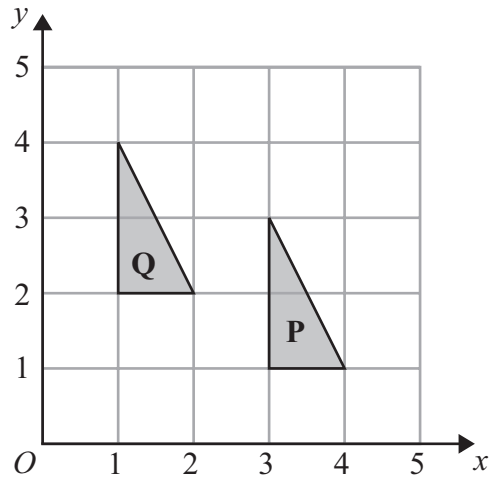

Describe fully the single transformation which maps triangle **P** onto triangle **Q**.

.....

.....

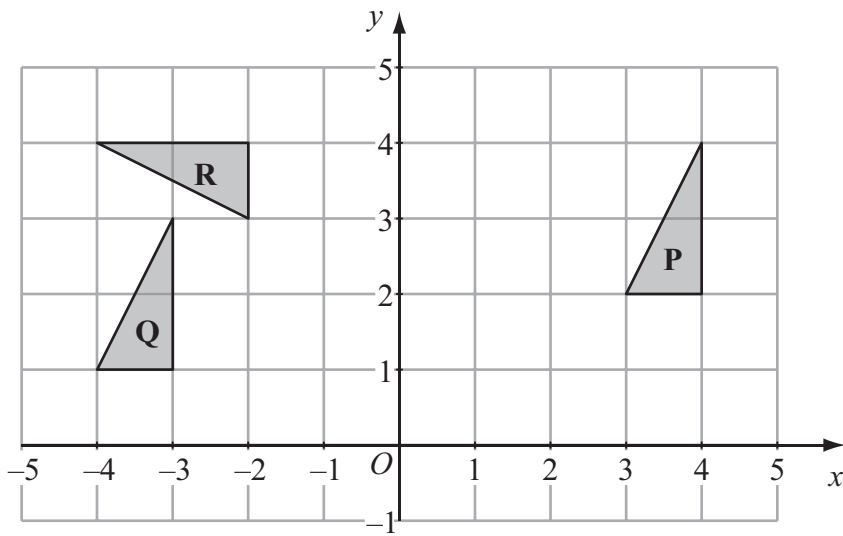

(a) Describe fully the single transformation which maps triangle **P** onto triangle **Q**.

.....

.....

(2)

(b) Describe fully the single transformation which maps triangle **P** onto triangle **R**.

.....

.....

(3)

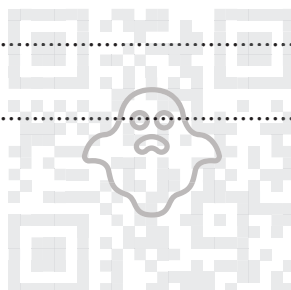

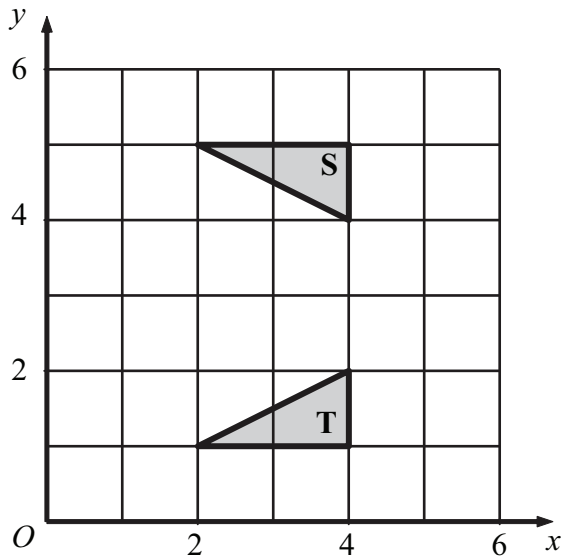

Describe fully the single transformation that maps triangle **S** onto triangle **T**.

.....

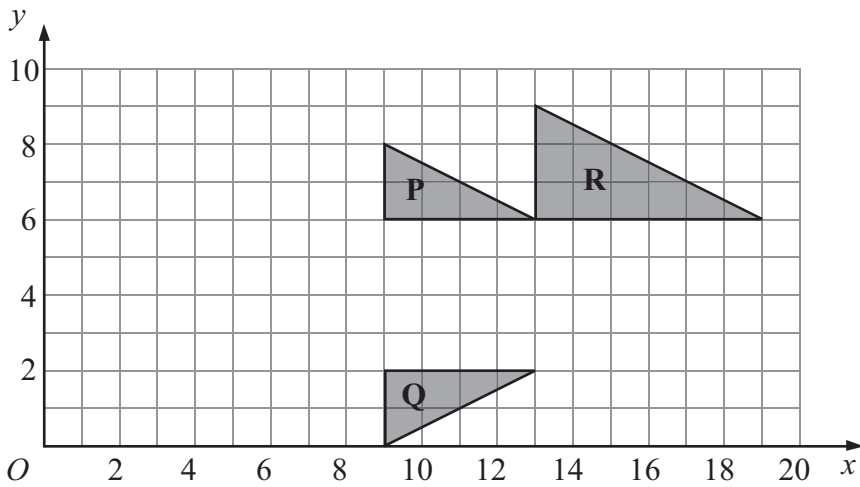

(a) Describe fully the single transformation which maps triangle **P** onto triangle **Q**.

..... (2)

(b) Describe fully the single transformation which maps triangle **P** onto triangle **R**.

.....  
 ..... (3)



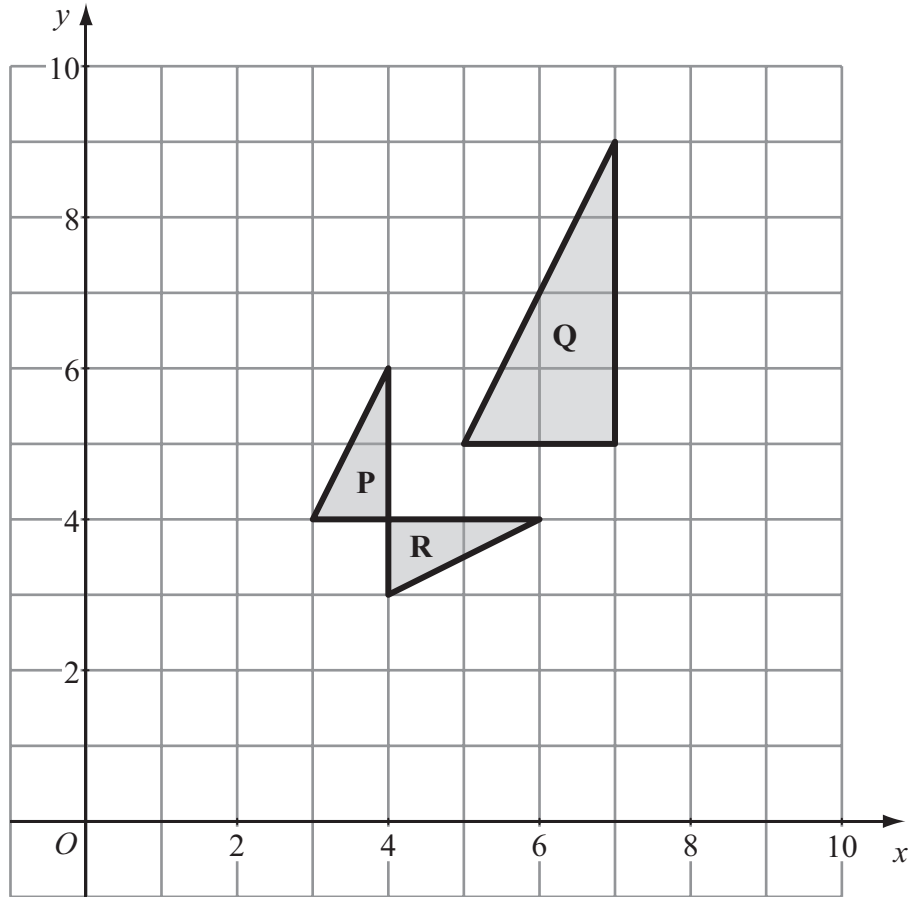

- (a) Describe fully the single transformation that maps triangle **P** onto triangle **Q**.

.....  
(3)

- (b) Describe fully the single transformation that maps triangle **P** onto triangle **R**.

.....  
(2)



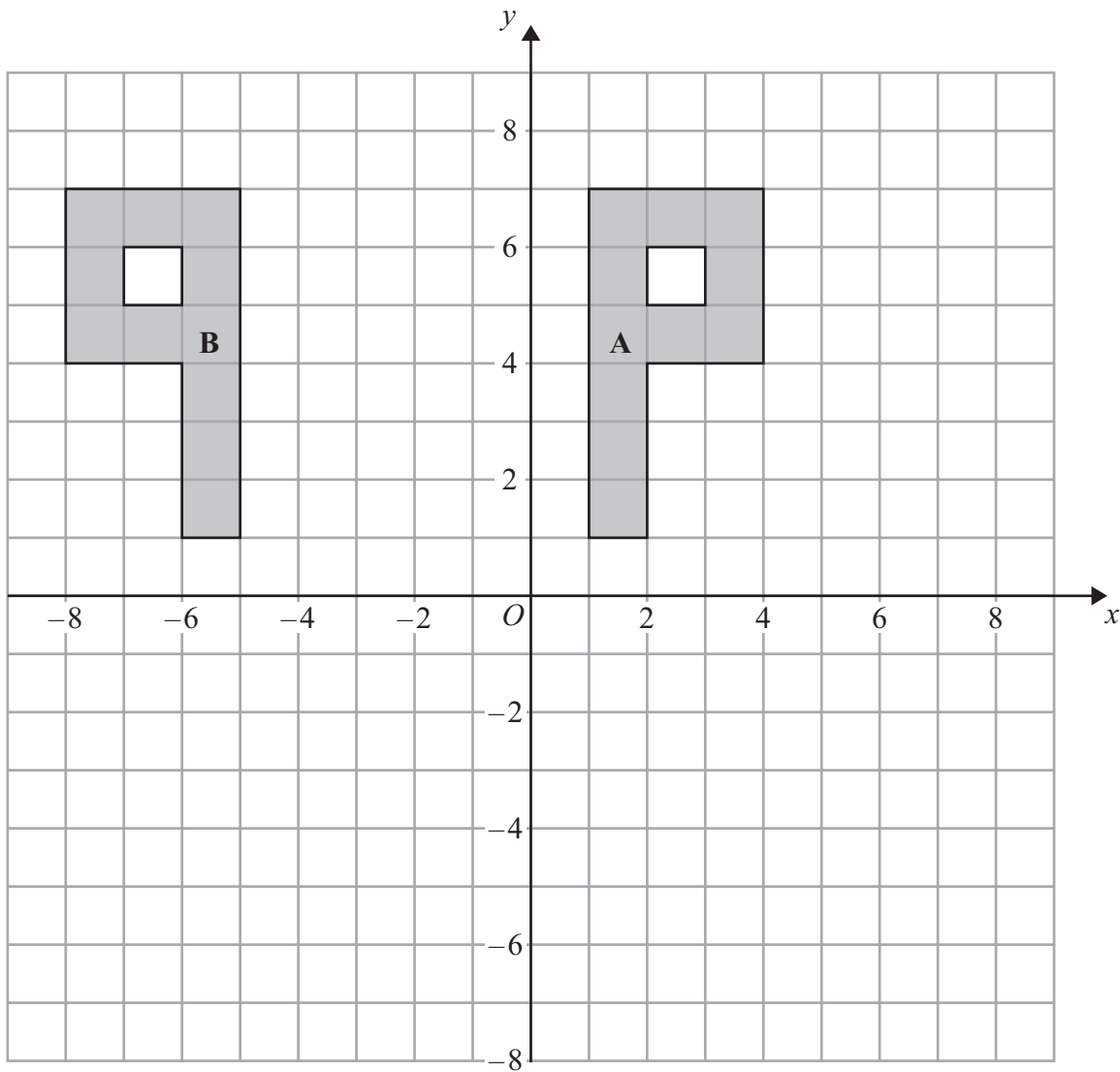

(a) Describe fully the single transformation that maps shape A onto shape B.

(2)

(b) On the grid, rotate shape A  $90^\circ$  clockwise about the origin  $O$ .  
Label the new shape C.

(2)



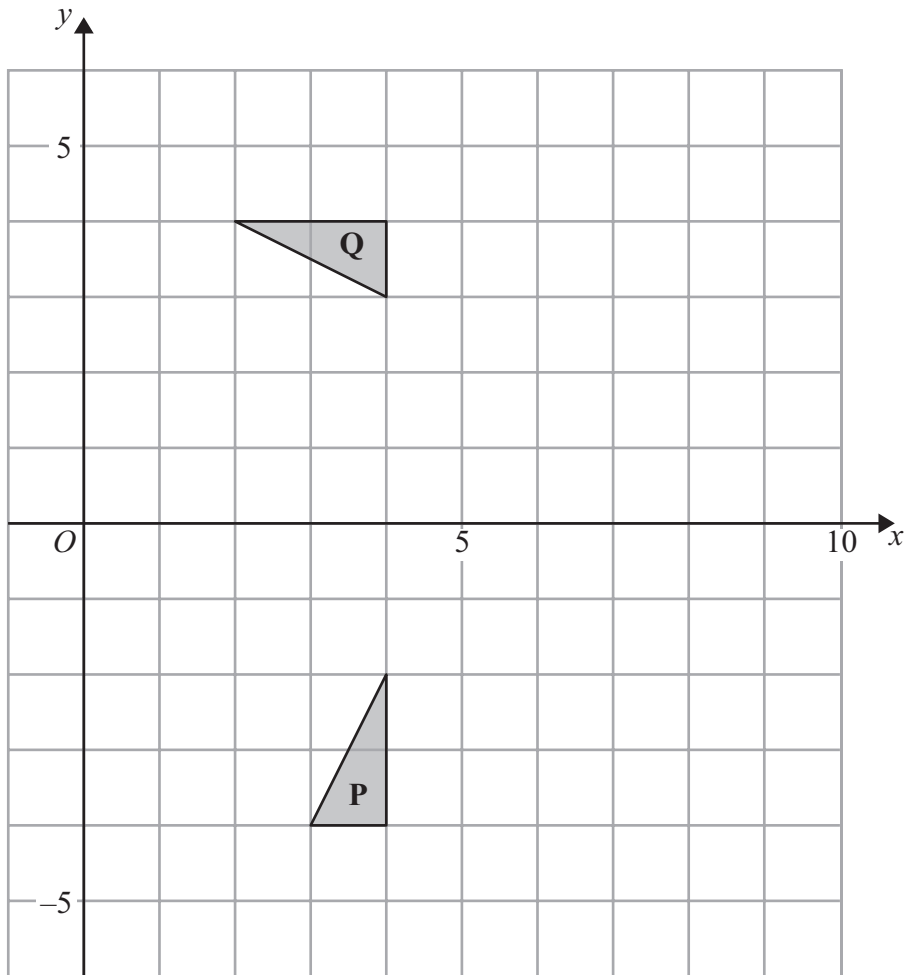

(a) Describe fully the single transformation that maps triangle **P** onto triangle **Q**.

(3)

(b) On the grid, translate triangle **P** 3 squares to the right and 5 squares up.  
Label the new triangle **R**.

(1)



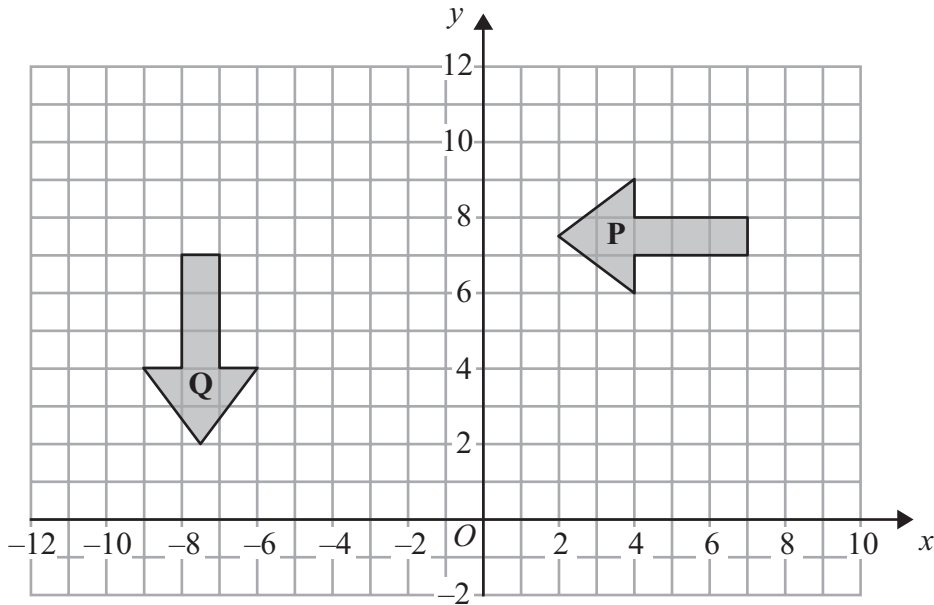

(a) Describe fully the single transformation that maps shape **P** onto shape **Q**.

.....  
 ..... (3)

(b) On the grid, translate shape **P** by the vector  $\begin{pmatrix} -6 \\ 2 \end{pmatrix}$   
 Label the new shape **R**.

(2)

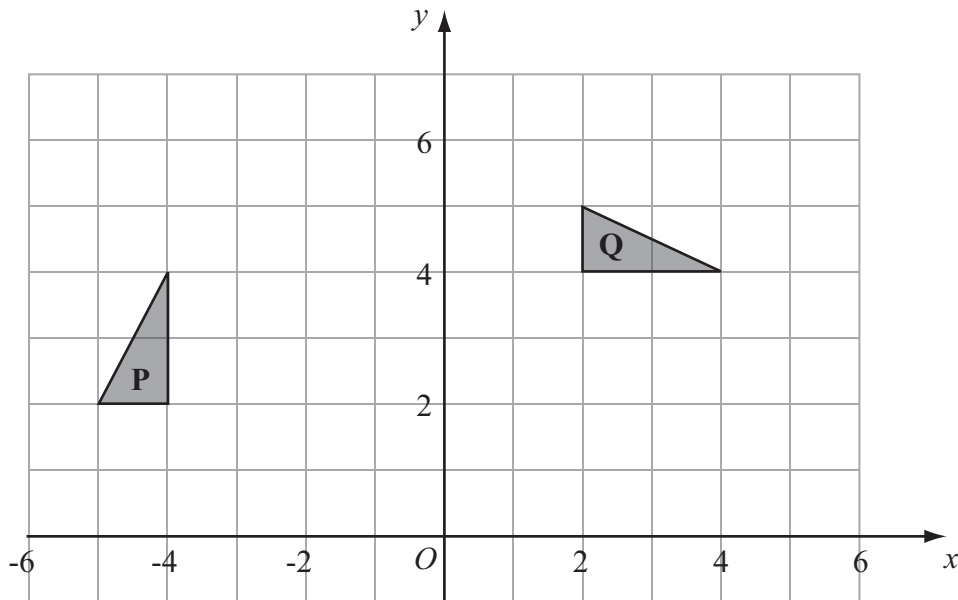

(a) Describe fully the single transformation which maps triangle **P** onto triangle **Q**.

..... (3)

(b) Reflect triangle **Q** in the line  $y = x$ .

Label the new triangle **R**.

(2)



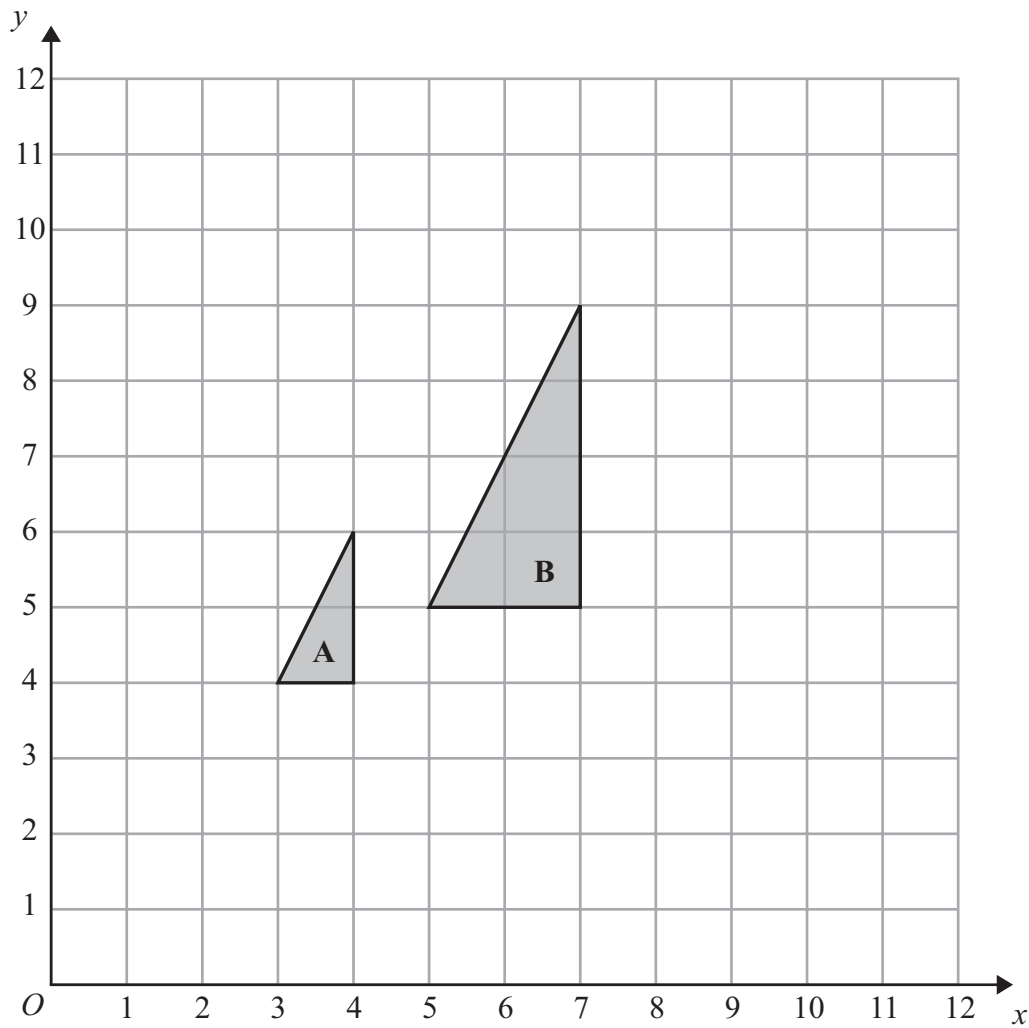

(a) Describe fully the single transformation that maps triangle **A** onto triangle **B**.

.....

.....

(3)

(b) On the grid, translate triangle **A** by the vector  $\begin{pmatrix} 5 \\ -2 \end{pmatrix}$

(1)





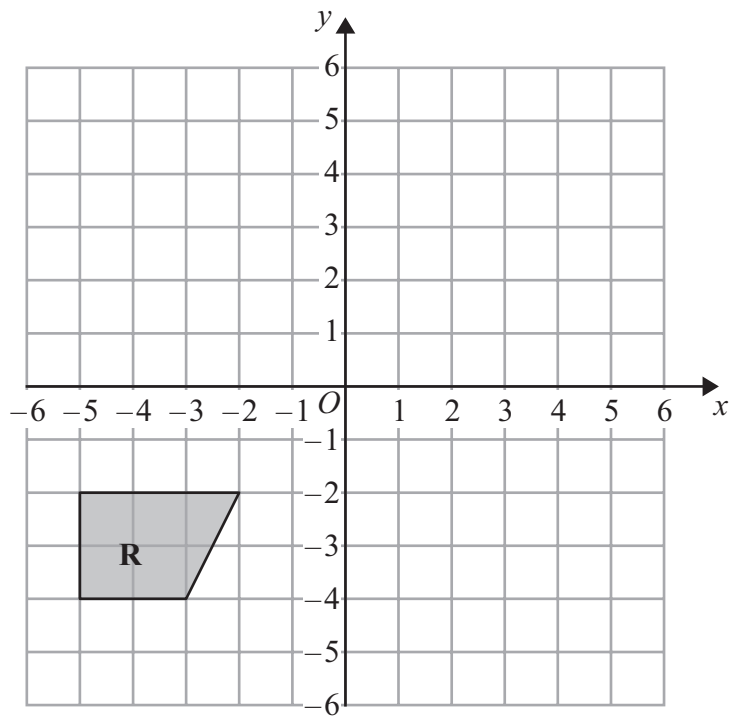

(a) On the grid above, reflect shape **R** in the line  $y = -x$

(2)

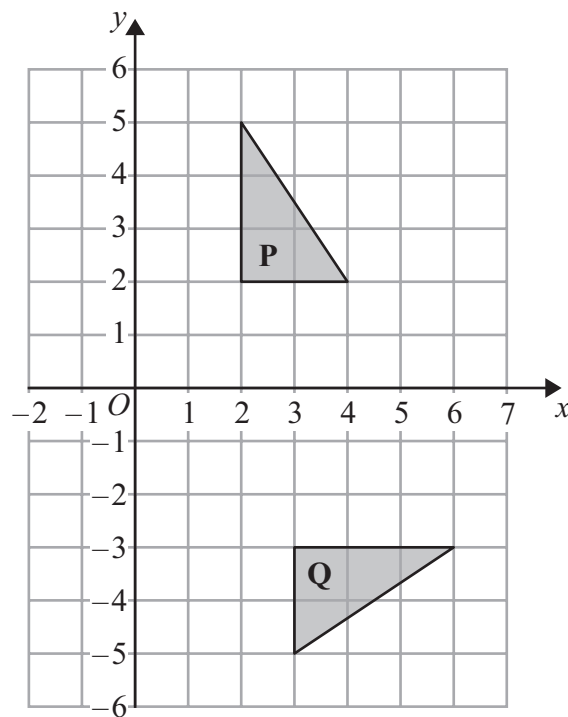

(b) Describe fully the single transformation that maps triangle **P** onto triangle **Q**.

.....

.....

(3)



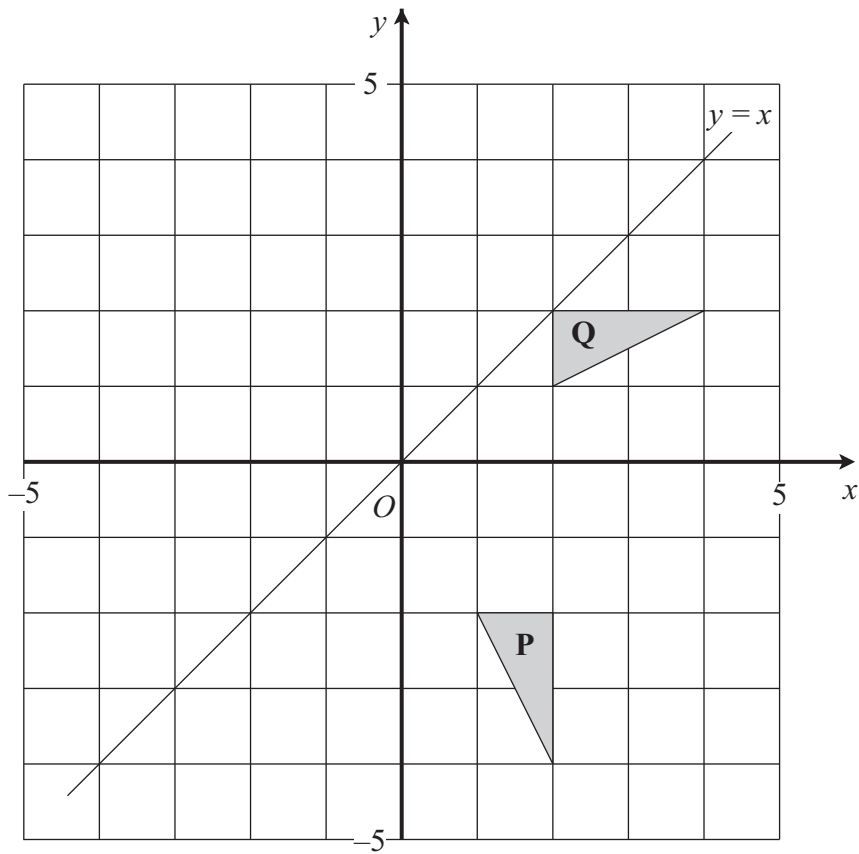

- (a) Describe fully the single transformation which maps triangle **P** onto triangle **Q**.

.....

.....

(3)

- (b) Reflect triangle **Q** in the line with equation  $y = x$ .

(2)



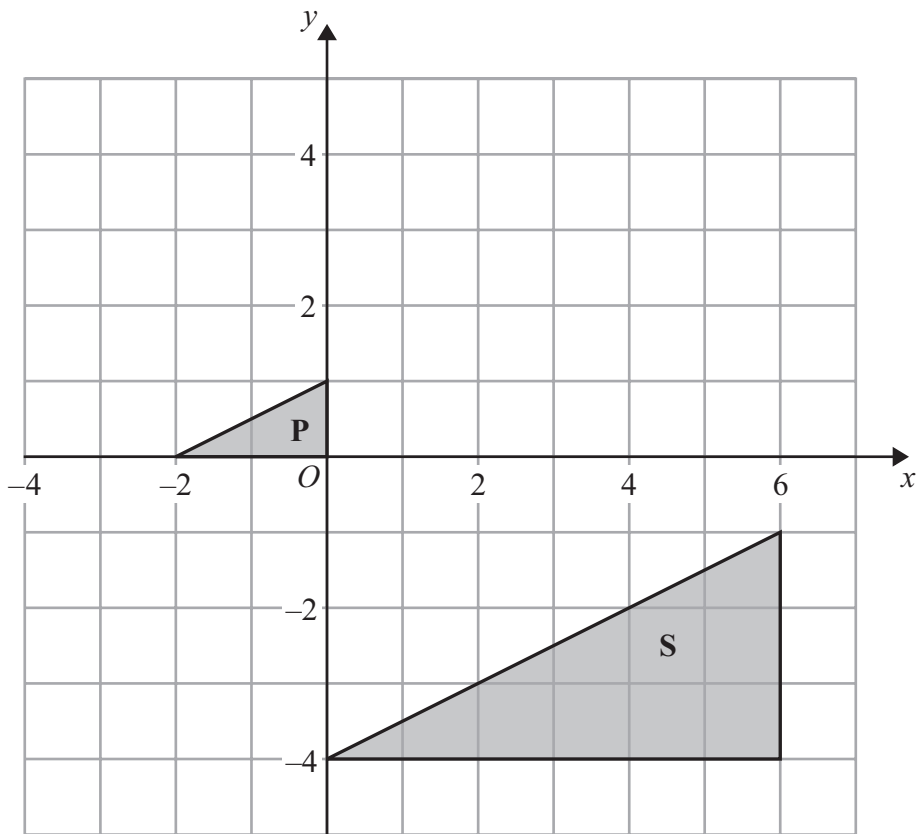

- (a) On the grid, translate triangle **P** by the vector  $\begin{pmatrix} 2 \\ -1 \end{pmatrix}$   
Label the new triangle **Q**.

(1)

- (b) Describe fully the single transformation that maps triangle **P** onto triangle **S**.

(3)



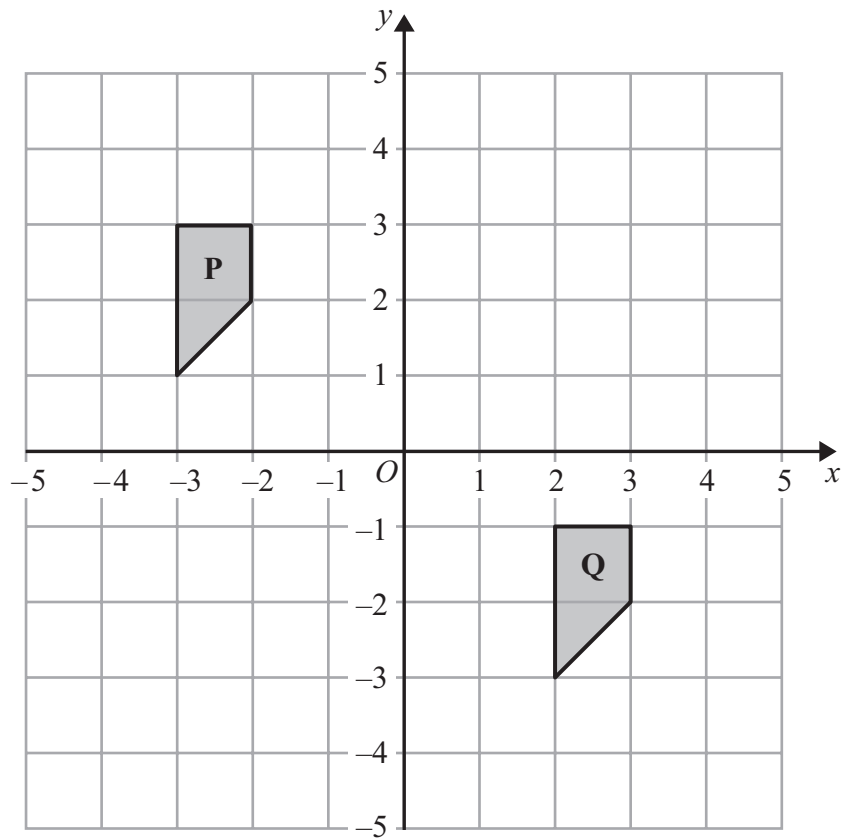

(a) Describe fully the single transformation that maps shape **P** onto shape **Q**.

.....  
 .....  
 (2)

(b) Rotate shape **Q**  $90^\circ$  clockwise about  $(1,0)$   
 Label the new shape **R**.

(2)



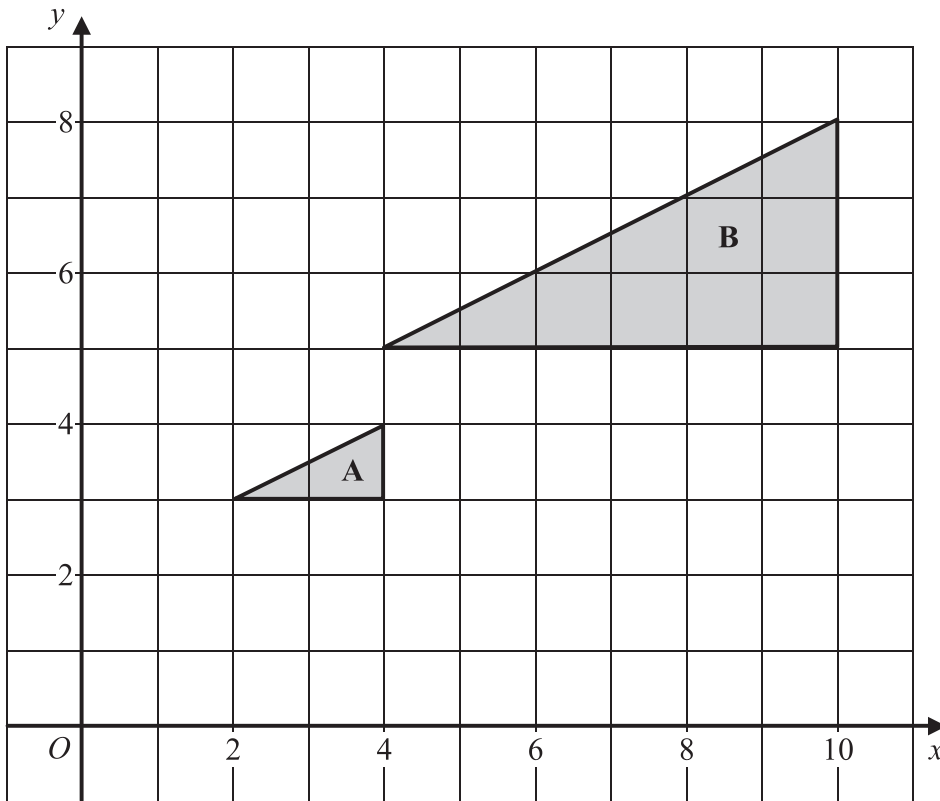

- (a) Describe fully the **single** transformation which maps triangle **A** onto triangle **B**.

.....

.....

(3)

- (b) On the grid, translate triangle **A** by the vector  $\begin{pmatrix} -1 \\ 3 \end{pmatrix}$ .

Label the new triangle **C**.

(2)



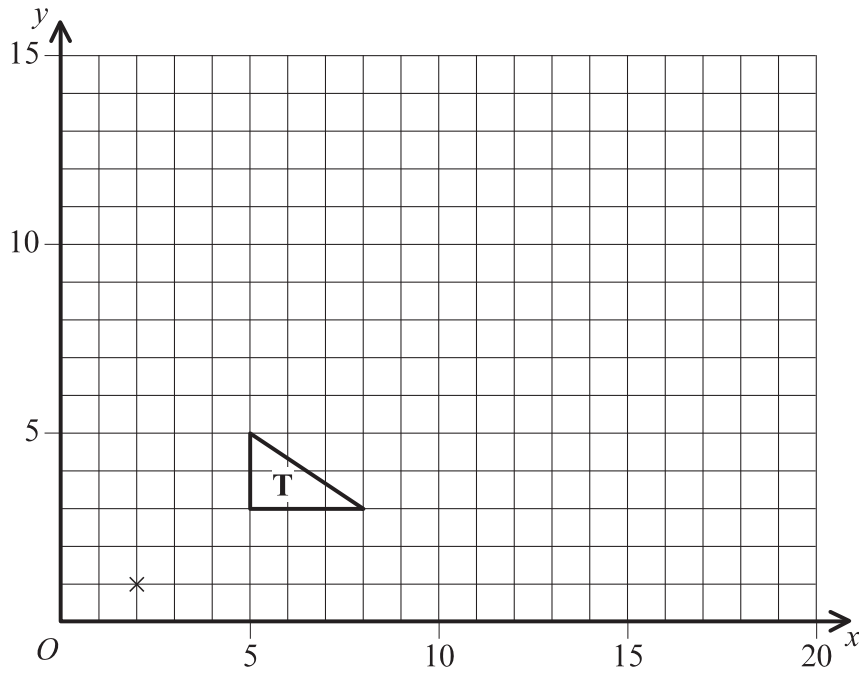

On the grid, enlarge triangle **T** with a scale factor of 3 and centre (2, 1).

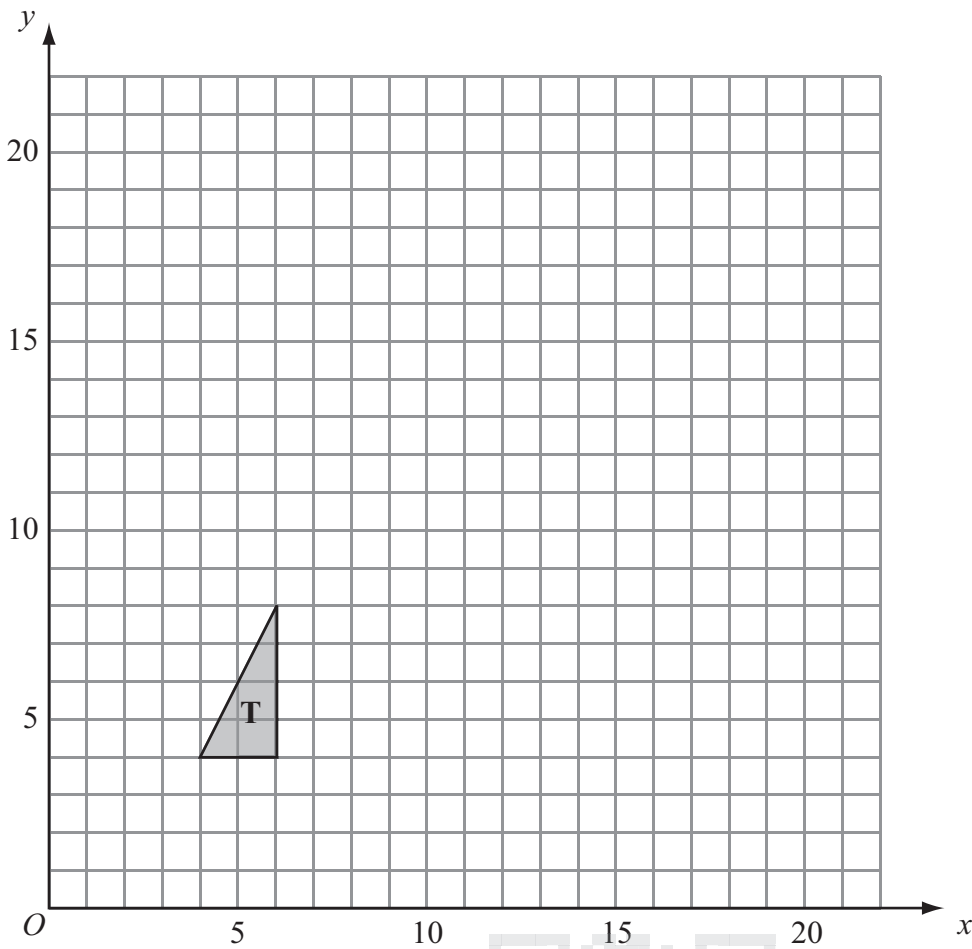

On the grid, enlarge triangle **T** with a scale factor of  $2\frac{1}{2}$  and centre (0, 0).

(a)

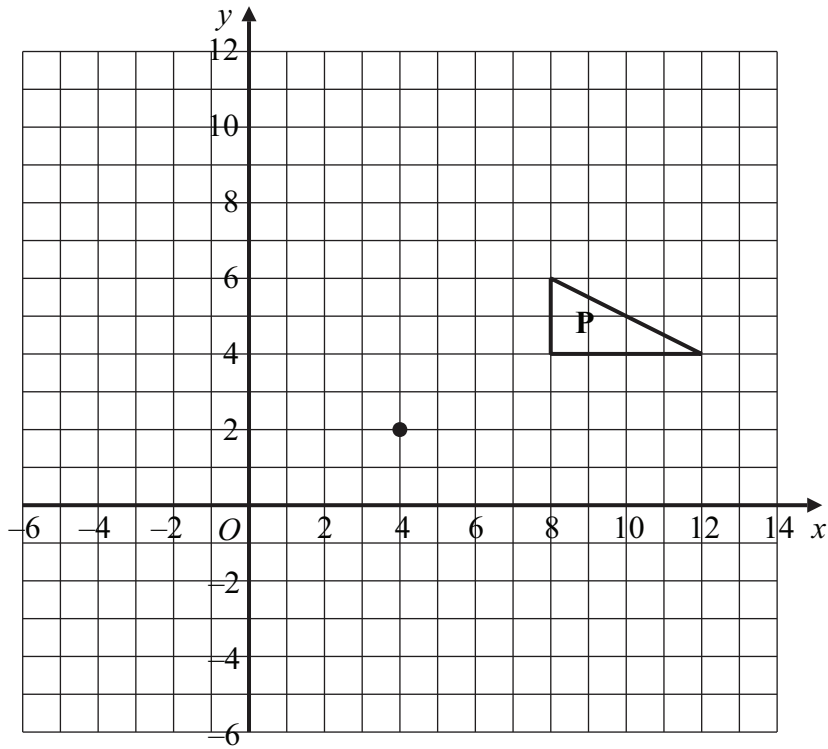

On the grid, rotate triangle P  $90^\circ$  anti-clockwise about the point (4, 2).

(2)

(b)

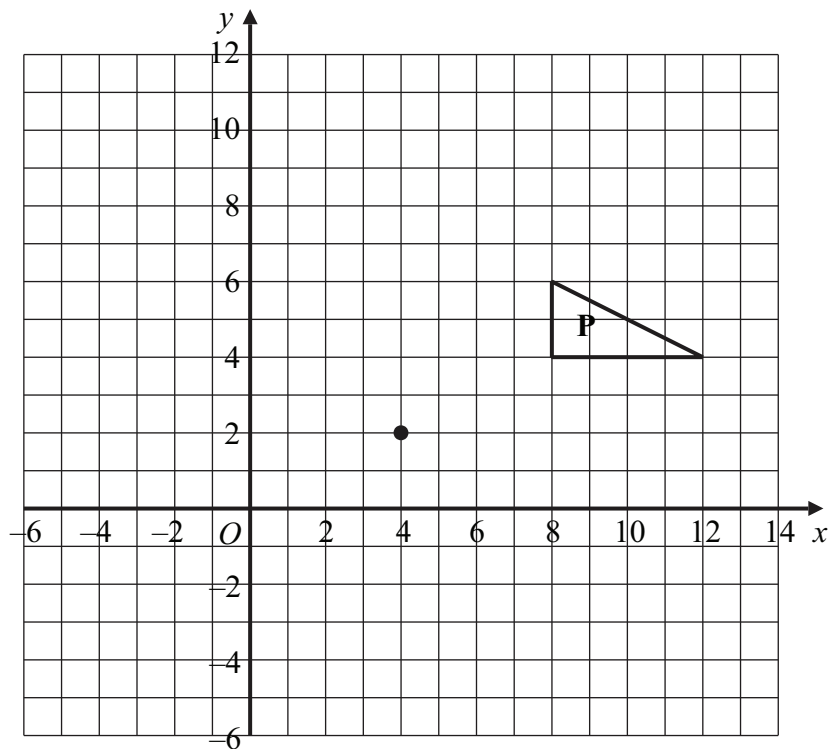

On the grid, enlarge triangle P with scale factor  $\frac{1}{2}$  and centre (4, 2).

(2)



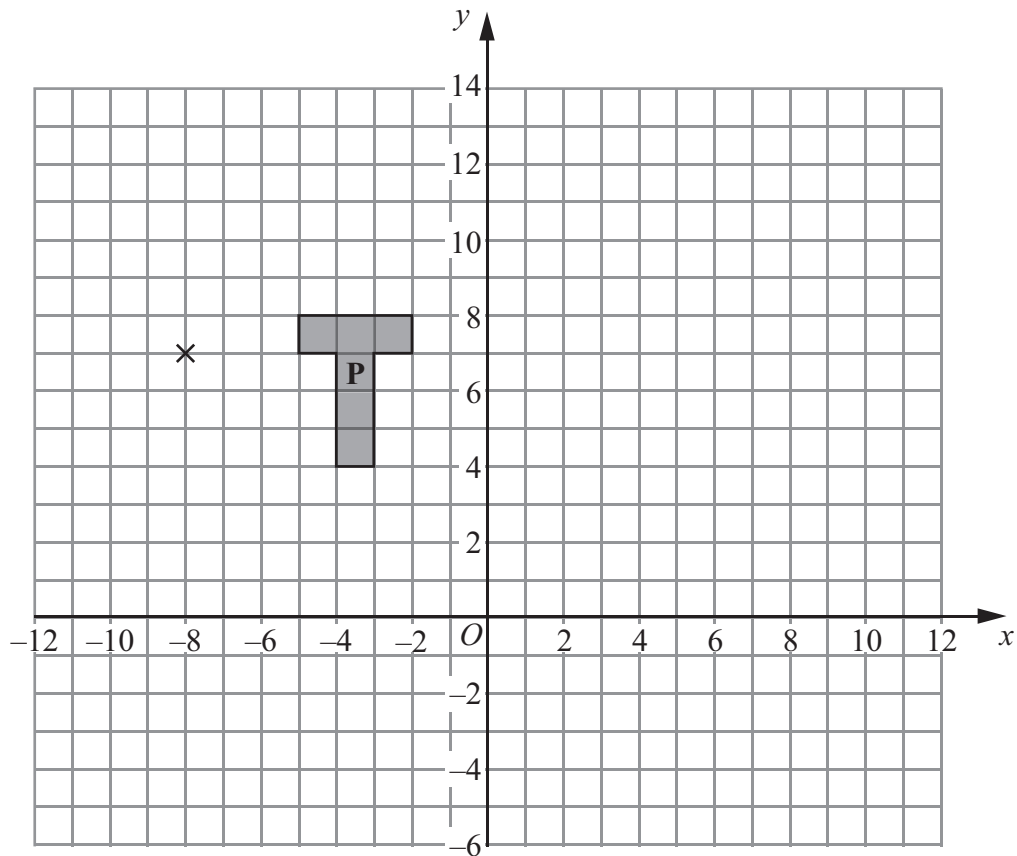

- (a) On the grid, enlarge shape **P** with scale factor 3 and centre  $(-8, 7)$ .  
Label the new shape **Q**.

(3)

- (b) On the grid, rotate shape **P** through  $90^\circ$  clockwise about the point  $(-8, 7)$ .  
Label the new shape **R**.

(2)

